



User Guide



DB2

HDCP compliant retractable monitors for furniture integration

Technology Serving Design

Danish craftsmanship
Mediterranean soul

ARTHUR HOLM

TABLE OF CONTENTS

REGULATIONS AND SECURITY	5
SAFETY INSTRUCTIONS	5
SYSTEM DESCRIPTION	7
INSTALLATION INSTRUCTIONS	11
CONTROLS	24
OSD MENU	27
ISD MENU	30
INPUT CONNECTORS	36
AHnet PROTOCOL	37
VIDEO SIGNALS	41
AHLink	42
INFORMATION ON DISPOSAL	45
WARRANTY TERMS AND CONDITIONS	46

WELCOME

Thank you very much for purchasing an Arthur Holm product.

Please, read these installation and operating instructions carefully and keep them in a safe place for future consultations.

We remain at your entire disposal if you have any suggestions.

Henrik Holm

General Manager

hholm@albiral.com

ABOUT US

The Company

Arthur Holm has its origins in the Danish furniture designer Jorgen Alex Jensen, who was active during the sixties and the seventies. His design inspiration and his concept of ergonomics have been continued by his family, who is the design force behind Arthur Holm product range. The result of combining Scandinavian design tradition with Mediterranean creativity, flexibility and emotion is a wide product range built on more than 25 years of craftsmanship.

Arthur Holm offers a professional product range where tomorrow's technology is shaped into valued materials with design flexibility and customisation, specially created to enhance communication in reception, collaboration, conference and meeting areas.

The art of customisation

Arthur Holm offers a range of ingenious products whose designs are based on quality materials and the latest technology. Products which endow meeting and conference rooms with silent, ergonomic, innovative and aesthetic solutions that integrate into the furniture, hang from the walls as works of art or are used as interactive points of information.

The world of Arthur Holm

Arthur Holm offers a selection of unique, elegant, versatile, flexible and ergonomic products that are being used in meeting and conference rooms, reception areas, huddle rooms, control rooms, auditoriums and public zones of leading companies throughout the world.

The numbers speak for themselves! We currently own 33 product patents, have presence in over 45 countries with products and solutions in more than 25,000 installations.

It will be our pleasure to work with you, designing your unique and personalised environment. Our broadcast electronic engineers will provide the latest technology while our design team will offer you the most exclusive appearance.

Our team puts its heart, passion and pride in all our designs.

EC REGULATIONS AND SECURITY



ATTENTION: Do not disassemble or modify the device in any way. This symbol warns of the presence of dangerous un-insulated voltages inside some of the components, of sufficient magnitude to expose people to risk of electronic shock.



This symbol draws attention to important use and maintenance instructions in the manual that accompanies the unit.



This symbol indicates that the equipment conforms to the norms established by the European Community.



This symbol indicates D.C. current.

SAFETY INSTRUCTIONS

Plugs

- Do not dismantle any part of the monitor power connector.
- Disconnect the power plug from the AC outlet when the monitor is not going to be used for an indefinite period of time.

Power and extensions cords

- Use the appropriate power cord with the correct plug type.
- Do not overload wall outlets or power cords.
- Make sure the total ampere passed through an extension cord does not exceed the maximum allowed by the cable used.
- Do not place anything on the power cord.
- Do not locate this product where a person may walk or trip over the cord.

SAFETY INSTRUCTIONS



Wiring connected to hazardous voltage requires installation by qualified personnel or the use of ready-made flexible cables.



For your security, your equipment must be connected to an electrical outlet with grounding connection protection.

Since the plug is used to disconnect the device, the operating electrical outlet must be in an easily accessible place.

Environment

- Install the equipment on an elevated, flat surface.
- Install the equipment in a ventilated area.
- Avoid exposing the equipment to:
 - Rain or water
 - Excessive heat, cold or humidity
 - Area exposed to direct sunlight
 - Dirty areas
 - Equipment generating strong magnetic fields
- Avoid placing open containers of liquid, near the equipment.
- Keep a minimum distance of 30 mm in order to have good ventilation.
- Never place above the device any sources of flames such as lighted candles, etc.
- If you are using the device in extreme weather conditions and/or tropical climates, the equipment should be installed in a room which ensures a reasonable level of temperature and humidity.
- To prevent damage the equipment must be firmly anchored to the surface, as shown on the installation instructions.

SYSTEM DESCRIPTION

General

Arthur Holm's DB2 is a motorised retractable monitor range that creates minimum impact on the furniture's design. It is easy to integrate, intuitive to use (one simple operation sensor located on the top of the monitor) and almost invisible (no cover plate, neatly streamlined into the furniture) when not in operation.

DB2 provides a harmonious silent drive with variable speeds. With a maximum thickness of 20 mm, this monitor range is elegant, beautiful from all angles and can be veneered for a seamless integration in the furniture, creating a long lasting user's experience and delivering an exceptional image's quality.

The monitors are equipped with AH-AMMC: an auto mechanical calibration movement system and the use of the Arthur Holm's ERT will enable the address configuration of all the monitors installed in a table by simply pressing a button. The AHlink app allows a wireless access to the test and adjustment functions without removing the unit from the table.

Highlights

- The smallest impact on the table surface
- One operation sensor on top of the aluminium housing
- Front double sided anti-reflective 2 sides coating 2 mm glass
- Energy saving, low consumption video controller
- AH-AMMC Auto mechanical movement calibration
- Wireless connectivity for setup and control
- No cover plate required
- 20 mm max thickness

SYSTEM DESCRIPTION

Available Models

MODEL	DESCRIPTION
AH10DB2	<p>HDCP compliant vertically retractable aluminium 10,1" Full HD monitor with 20 degrees of adjustable inclination. Solid aluminium monitor housing with 17 mm. of thickness featuring 2 mm. double sided anti reflective black edged glass. Allows its installation in a furniture opening of a maximum width of 21 mm and the monitor housing is flush with the desk once in recessed position. One capacitive sensor is located on top of the aluminum frame. DVI-I and DVI-D inputs, RS-422 I/O, ISD (Interactive Setup Display), USB port for firmware upgrades, AH-AMMC (Auto-mechanical movement callibration).</p>
AH17DB2	<p>HDCP compliant vertically retractable aluminium 17,3" Full HD monitor with 20 degrees of adjustable inclination. Solid aluminium monitor housing with 20 mm. of thickness featuring 2 mm. double sided anti reflective black edged glass. Allows its installation in a furniture opening of a maximum width of 24 mm and the monitor housing is flush with the desk once in recessed position. One capacitive sensor is located on top of the aluminum frame and a second touch sensor on the screen's glass. DVI-I and DVI-D inputs, RS-422 I/O, ISD (Interactive Setup Display), USB port for firmware upgrades, AH-AMMC (Automechanical movement callibration).</p>
AH22DB2	<p>HDCP compliant vertically retractable aluminium 21,5" Full HD monitor with 20 degrees of adjustable inclination. Solid aluminium monitor housing with 20 mm of thickness featuring 2 mm. double sided anti reflective black edged glass. Allows its installation in a furniture opening of a maximum width of 24 mm. and the monitor housing is flush with the desk once in recessed position. One capacitive sensor is located on top of the aluminum frame and a second touch sensor on the screen's glass. DVI-I and DVI-D inputs, RS-422 I/O, ISD (Interactive Setup Display), USB port for firmware upgrades, AH-AMMC (Automechanical movement callibration).</p>

SYSTEM DESCRIPTION

Options

AH10DB2	AH17DB2	AH22DB2
TS10DB2 Projected capacitive multitouch screen	TS17DB2 Projected capacitive multitouch screen	TS22DB2 Projected capacitive multitouch screen
CABDB2 (Min.10 units) Black anodised	CABDB2 (Min.10 units) Black anodised	CABDB2 (Min.10 units) Black anodised
GFDB2 (Min.10 units) Gold finish	GFDB2 (Min.10 units) Gold finish	GFDB2 (Min.10 units) Gold finish
BFDB2 (Min.10 units) Bronze finish	BFDB2 (Min.10 units) Bronze finish	BFDB2 (Min.10 units) Bronze finish
CPDB2 (Min.10 units) Painted	CPDB2 (Min.10 units) Painted	CPDB2 (Min.10 units) Painted
ACP (Min.10 units) Aluminium cover plate	ACP (Min.10 units) Aluminium cover plate	ACP (Min.10 units) Aluminium cover plate
AHDL DynamicLoop	AHDL DynamicLoop	AHDL DynamicLoop

SYSTEM DESCRIPTION

Box Contents

Before the installation of your retractable monitor, please check the contents of the shipping box, it must contain the following items:

- Monitor
- Power cord
- Remote control (1 per 5 monitors)
- Power supply 100-240Vac, 50-60Hz. Output 12V
- User guide

Important note: This device can only work with the power supply included in the shipping box. This power supply can not be replaced by any other rather than the original one.

Connections

Before connecting the power:

1. Install the unit on a table or desk, in vertical position.
2. Remove the foam protecting piece before connecting the monitor.

Power connection:

1. Plug the power cable from the power supply into an AC socket of 100-240 Vac, 50-60Hz.
2. Plug the 12V D.C.  cable into the socket on the unit.



Caution! Never place this monitor in horizontal position.

INSTALLATION INSTRUCTIONS

The DB2 monitor is designed to be mounted from below the table. Included in this version are all necessary brackets.

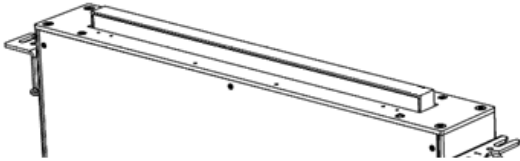

Pattern Hole

Pattern hole dimensions for milling are specified in the corresponding drawing. The milling of the furniture has to be done from below.

Attention

Manipulation of the product should be avoided, no stress should be applied to the product except from the instructions given in this document. Cutting, drilling, soldering, adding electrical and mechanical components can cause danger and should be avoided by all means. Not complying with these directions will result in a loss of the Arthur Holm warranty. Albiral Display Solutions S.L. shall not be held liable for any loss or injury incurred as a result of modifications made to goods by anyone other than the supplier or the supplier's authorised representative with the supplier's written permission. Such modifications shall be deemed to terminate any further guarantee obligations.

INSTALLATION INSTRUCTIONS

Mounting table brackets

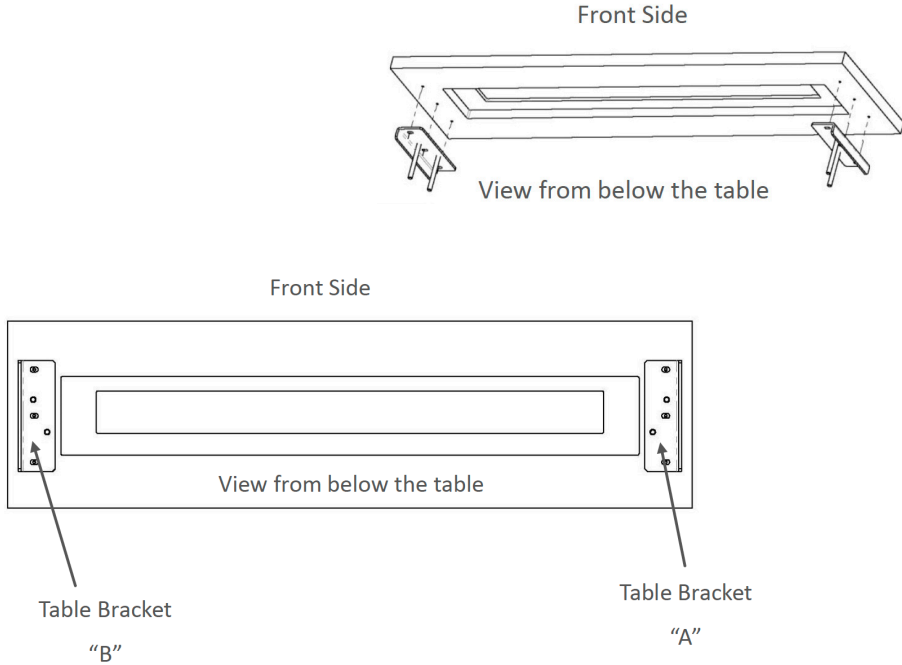

Mount the table brackets below the table using the holes indicated IN the corresponding Pattern Hole drawing. The screws (x6) are not supplied. The weight of the monitor is up to 25Kg / 55.16 Lbs.

PAY ATTENTION THAT THE BRACKETS ARE MOUNTED IN THEIR CORRESPONDING SIDE.

INSTALLATION INSTRUCTIONS

Mounting the monitor brackets

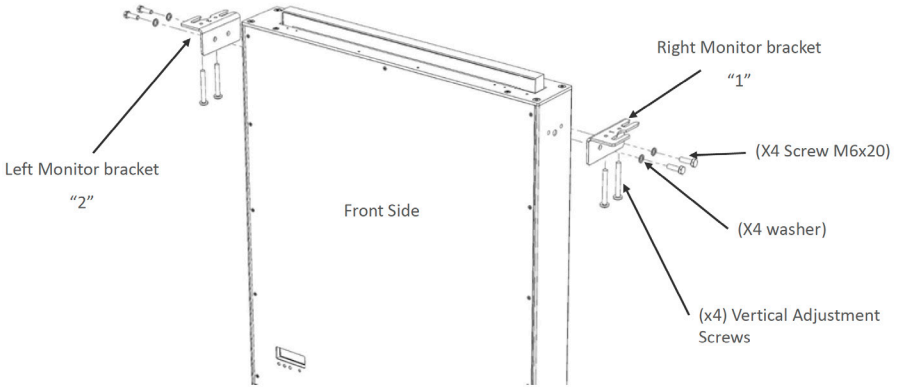

Mount the monitor brackets in their corresponding side using the supplied screws.

Mount the vertical adjustment screws (2+2) on to the monitor bracket so that the tip of the screw is flushed with the upper side of the monitor bracket.

INSTALLATION INSTRUCTIONS

Checking assembly

View from below the table:

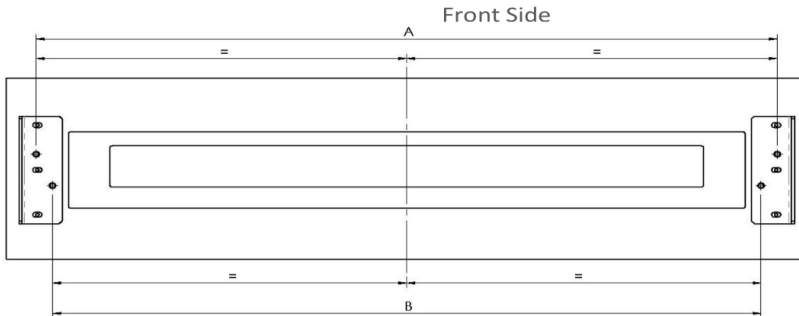

View from above the monitor:

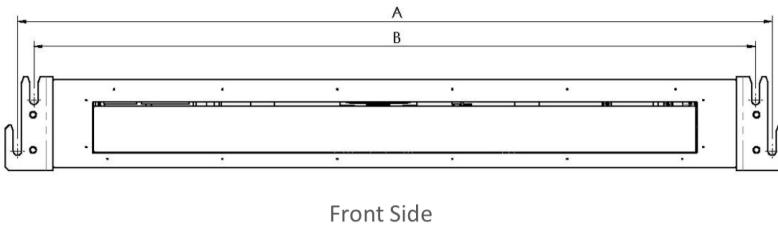

Dimensions A and B in table brackets and in monitor brackets must be the same (+1mm).

If adjustment is necessary loosen 3+3 Table bracket screws, keeping always symmetry regarding to the monitor hole in the table. Subsequently, tighten the table bracket screws.

INSTALLATION INSTRUCTIONS

Hanging the monitor

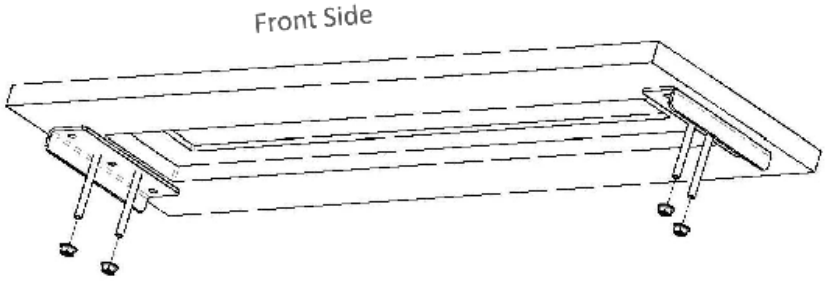

Mount 2+2 nuts on to both table brackets as indicated in the drawing.

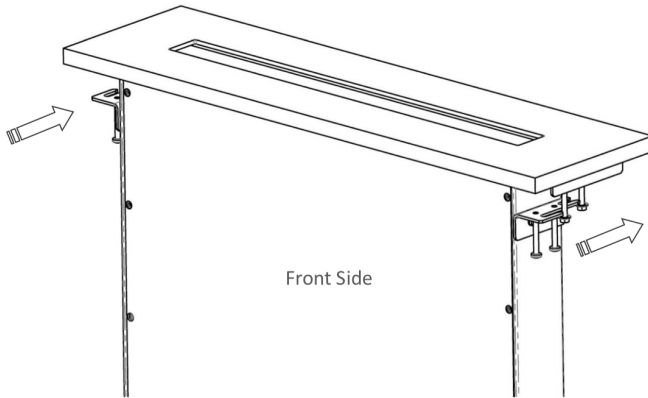

Hang the monitor above nuts.

INSTALLATION INSTRUCTIONS

Centring the monitor

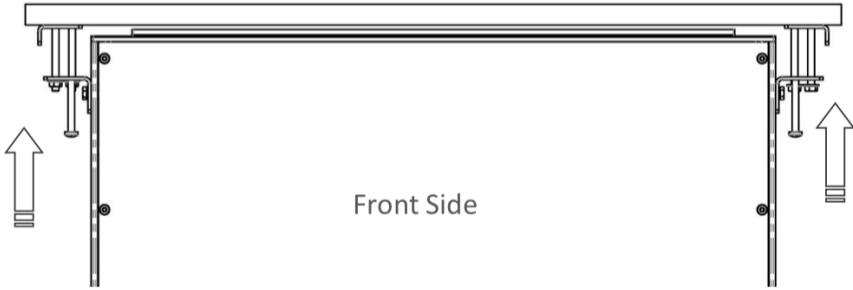

Tighten each nut gradually until the monitor surface is levelled with the table surface.

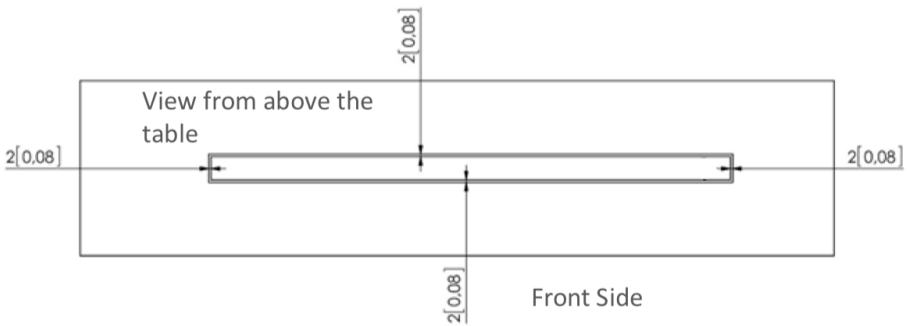

Air gap around the monitor have to be 2mm [0,08]. Otherwise the monitor could come in contact with the table while opening and be damaged.

INSTALLATION INSTRUCTIONS

Fine centring of the monitor

In case fine centring of the monitor is necessary:

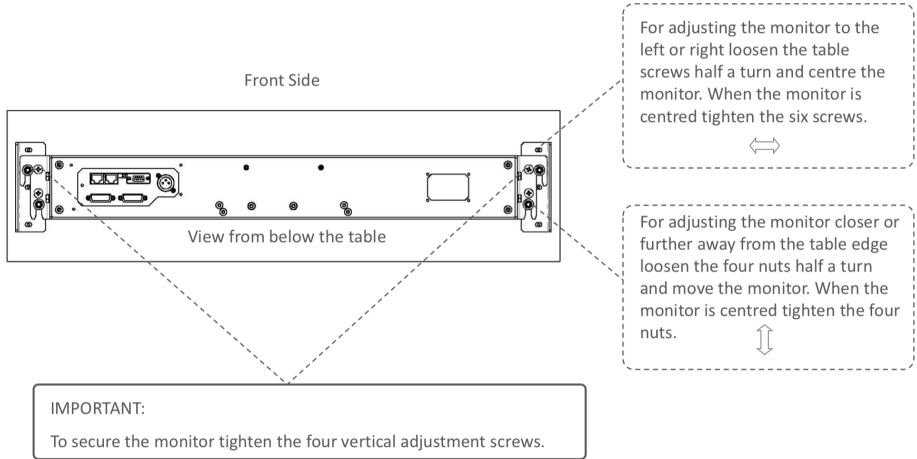

Veneer Guide

The DB2V is prepared to be mounted from below the table with a Veneer finishing on the top of the monitor to match the table. The Veneer is not supplied. The Veneer option (V1, V2, V3) are available under request.

INSTALLATION INSTRUCTIONS

Veener

The Veener can be placed in three ways:

Option V1:

Veener: The veneer thickness must be 4mm [0,15] and the copper cylinder will be leveled with table surface.

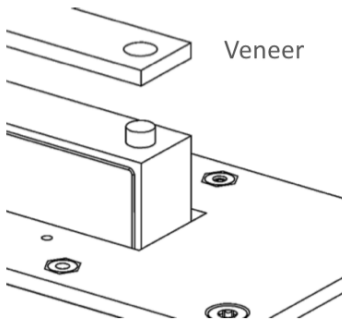

Option V2:

Veener + Distance Plate: For Veneers Thickness of 1mm [0,04] or less. It will be necessary a Distance Plate to hide the touch button copper cylinder.

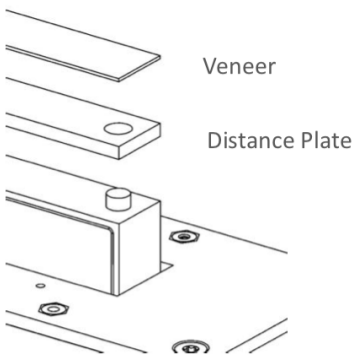

INSTALLATION INSTRUCTIONS

Option V3:

Veneer: The veneer thickness must be 5mm [0,19]. A mechanised blind hole will be necessary to hide the touch button copper cylinder.

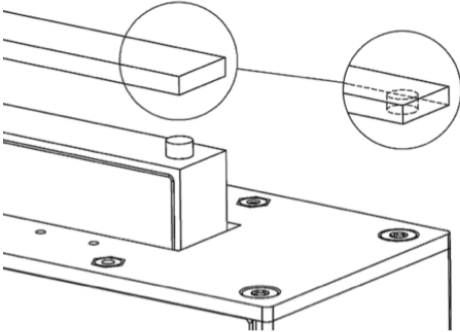

INSTALLATION INSTRUCTIONS

Option V1:

- Double side tape or glue used can't be thicker than 0,2-0,25mm [0.008 0.01]

1. Check if the Veneer fits perfectly with the monitor. To join both parts correctly it is important that the two surfaces are touching each other in the whole length. (To make easier the adjustment the height of the touch button can be barely adjusted.)

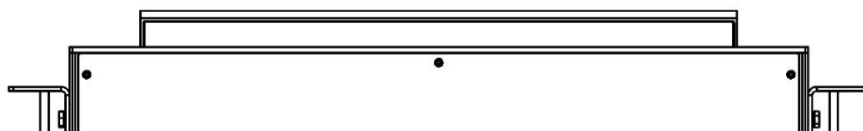

2. Clean the top surface of the metal monitor housing and the bottom surface of the Veneer.

3. Glue the Veneer. Double-side tape or glue can be used (depending on the kind of materials are going to be jointed). The pressure applied must not exceed 1 Kg evenly distributed on monitor surface.

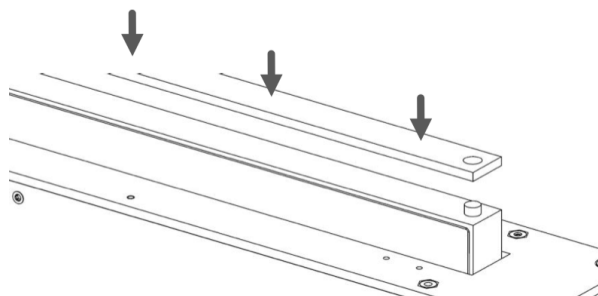

INSTALLATION INSTRUCTIONS

Option 1 Cut-Out:

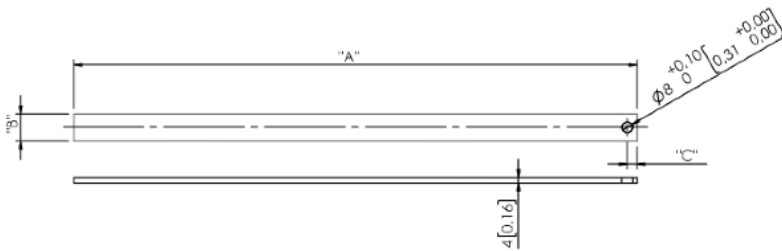

	AH10DB2	AH17DB2	AH22DB2	AH24DB2
"A"	258[10.15]	424[16.7]	518[20.39]	559,2[22]
"B"	17[0.67]	20[0.78]	20[0.78]	20[0.78]
"C"	8[0.31]	7,5[0.29]	7,5[0.29]	10[0.39]

Option V2:

- Distance Plate material can't be metallic. Wood or DM are advisable.
- Veneer material can't be conductor.

1. Check if the Distance Plate fits perfectly with the monitor. The copper cylinder can't project outwards from the Distance Plate surface. To make easier the adjustment the height of the copper cylinder can be barely adjusted.

2. Clean the top surface of the metal monitor housing and the bottom surface of the Distance Plate.

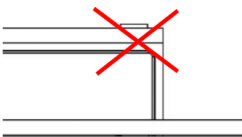

3. Glue the Veneer. Double-side tape or glue can be used (depending on the kind of materials are going to be jointed). Double- side tape or glue used can't be thicker than 0,2 0,25mm [0.008 0.01]

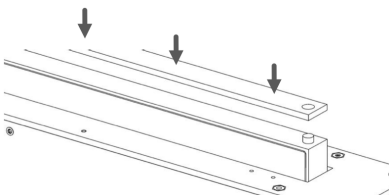

The pressure applied must not exceed 1 Kg evenly distributed on monitor surface.

INSTALLATION INSTRUCTIONS

4. Clean the top surface of the Distance Plate and the bottom surface of the Veneer.

5. Glue the Veneer. Double side tape or glue can be used (depending on the kind of materials are going to be The total thickness of Veneer + glue used can't be thicker than 1mm [0.04].

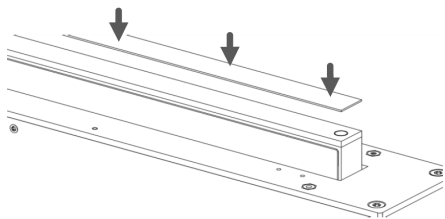

Option 2 Cut-Out:

DB2 Veneer cut-out:

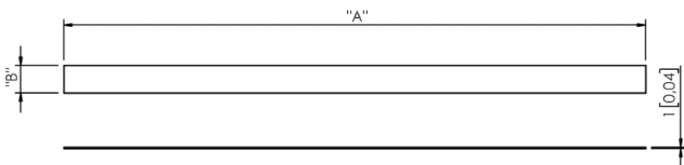

DB2 Distance plate cut-out:

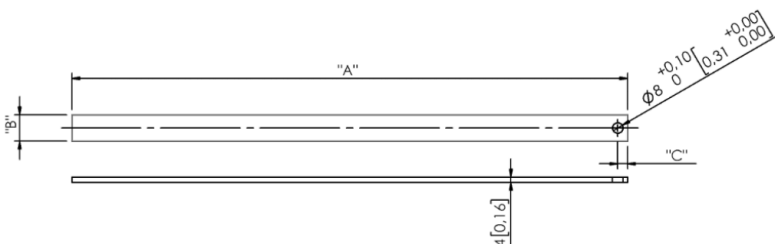

	AH10DB2	AH17DB2	AH22DB2	AH24DB2
"A"	258[10.15]	424[16.7]	518[20.39]	559,2[22]
"B"	17[0.67]	20[0.78]	20[0.78]	20[0.78]
"C"	8[0.31]	7,5[0.29]	7,5[0.29]	10[0.39]

INSTALLATION INSTRUCTIONS

Option V3:

- Veneer material can't be conductor.

1. Check if the Veneer fits perfectly with the monitor. To join both parts correctly it is important that the two surfaces are touching each other in the whole length. If there is a gap between the Veneer and the monitor, check if the hole depth in the Veneer is correct. (To make easier the adjustment the height of the copper cylinder can be barely adjusted.)

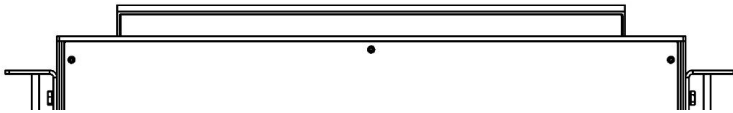

2. Clean the top surface of the metal monitor housing and the bottom surface of the Veneer.

3. Glue the Veneer. Double side tape or glue can be used (depending on the kind of materials are going to be jointed). Double side tape or glue used can't be thicker than 0,2 - 0,25mm [0.008 0.01]

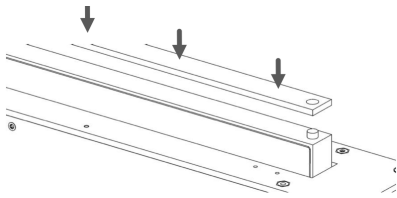

The pressure applied must not exceed 1 Kg evenly distributed on monitor surface.

Veneer Option 3 Cut-Out:

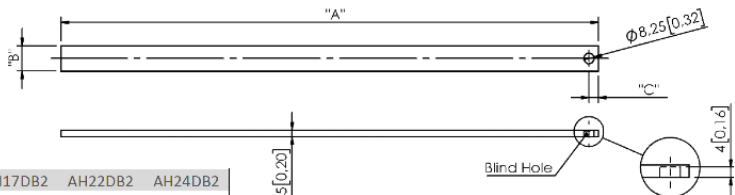

	AH10DB2	AH17DB2	AH22DB2	AH24DB2
"A"	258[10.15]	424[16.7]	518[20.39]	559,2[22]
"B"	17[0.67]	20[0.78]	20[0.78]	20[0.78]
"C"	8[0.31]	7,5[0.29]	7,5[0.29]	10[0.39]

CONTROLS

IR sensor

The IR sensor is located on the lower side of the screen.

Monitor movement controls

On the upper panel body, and on front glass, there is a button to control the down monitor movements, and the screen tilting angle.

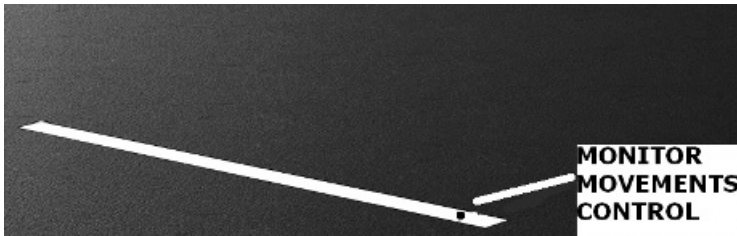
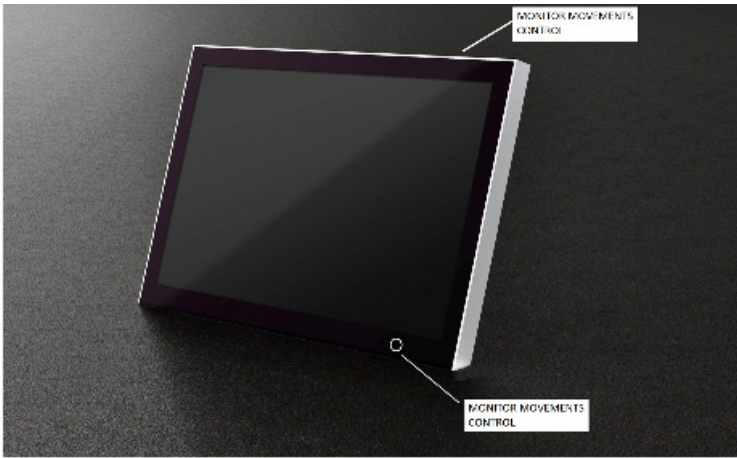

CONTROLS

1. Raising the monitor:

Press the sensor located on the top of the monitor to raise the display. Make sure that no objects are located on top of the monitor.

2. Tilting the screen:

Press and hold the sensor on the top of the monitor to adjust the desired tilt angle.

3. Retracting the monitor:

Press the button on the lower part of the screen to retract the monitor.

CONTROLS

Remote control

POWER	Switch ON/OFF the monitor
MENU	Activates the OSD menu on screen
UP	Control up on the OSD menu
DOWN	Control down on the OSD menu
LEFT	Control left on the OSD menu
RIGHT	Control right on the OSD menu
OK	Selects the function on the OSD menu. When the OSD menu is not active on screen, selects the input source

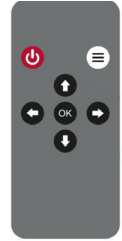

OSD MENU

Accessing the menu system

- With the OSD off, push the MENU button to activate the main OSD menu.
- Press the UP and DOWN buttons to move from one function to another. Please refer to the following sections below to view a complete list of all the functions available for the monitor.
- Press the OK button to confirm.
- When a function is selected, press the LEFT and RIGHT buttons in order to change the parameter of the function.

Press the MENU button to access to the main menu.

Picture

Picture Mode: Adjusts the mode of the image

- Dynamic
- Standard
- Mild
- User: Contrast - Brightness - Colour - Sharpness - Tint

Colour Temperature: Adjusts the colour of the image

- Cool
- Medium
- Warm
- Use: Red - Green - Blue

Aspect Ratio: Adjusts the image aspect on screen

- 4:3
- 16:9
- Just scan

OSD MENU

Noise Reduction: Adjusts the image noise filter

- Off
- Low
- Medium
- High
- Default

Screen: (Only for analogue signals)

- Auto Adjust
- Horizontal Position
- Vertical Position
- Size
- Phase

Backlight: Adjusts the backlight screen's level

Colour Range: Adjusts the colour range

- 0 - 255
- 16 - 235

OSD MENU

Option

Language: OSD language selection

Restore Factory Default: Adjusts the parameters to the initial factory parameters

Blending: OSD window transparency

- Low
- Medium
- High
- Off

OSD Duration: Adjusts the time that the OSD menu window remains on the screen

Software Update (USB): Port to use for firmware's upgrade.

Mirror:

0. Image with no flip
1. Vertical flip
2. Horizontal flip
3. Rotate

ISD MENU

The Interactive Setup Display is an LCD screen located at the monitor casing inside the desk that allows the setup and provides useful diagnose and historical data of the device.

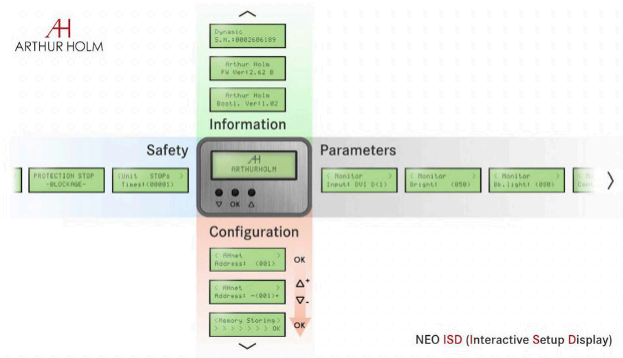

- To start using it -

• WELCOME DISPLAY & DATA :

1) Bootloader Version

The display will show a Bootloader Version message (example: Bootl. Ver: 1.01). Bootloader is a program which allows the system to be able to update itself. The ISD has a Bootloader and therefore is capable of updating to new versions in order to constantly improve the user experience.

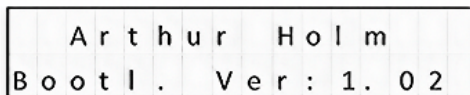

ISD MENU

2) FirmWare

Data that refers to the firmware version (FW) of the equipment (example: FW Ver = 1.32). If you wish to update the FW version, please contact us.

```
  A r t h u r   H o l m  
F W V e r : 1 . 2 6
```

3) Serial Number

Serial number of the device (example: serial number of the device = 02658748). The serial number is stored inside each device.

```
D y n a m i c _ 2  
S . N . : 0 1 2 3 4 5 6 7 8 9
```

The serial number can also be obtained via AHnet and AHlink.

- OSD MENU -

· AHNET (GENERAL PROTOCOL)

CONTROLS

· The ISD will show the AHnet address which will be accompanied by an acoustic signal "BEEP" (example: Address: (001)). Once the signal has been heard, the "UP & DOWN" buttons will allow the user to scroll through all the variety of menus that the device contains. To enter into any specific menu, simply press the "OK" button.

```
<  A H n e t  >  
A d d r e s s :   ( 0 0 1 )
```

· How to modify the values within each menu? The values can be selected through the "UP & DOWN" buttons. To save the selected value, press the "OK" button or wait 3 seconds for it to be automatically saved.

```
<  A H n e t  >  
A d d r e s s :   - ( 0 0 1 ) +
```

The connection through RS422 allows the control of up to 30 devices per line. The last device (an only the last one) needs to have the termination activated.

ISD MENU

· MENUS GENERAL INFORMATION

1) AHnet - Adress

The address must be set from 1 to 60.

```
<  A H n e t  >  
A d d r e s s :   ( 0 0 1 )
```

2) VIDEO INPUT SELECTION

The device provides the following inputs:

DVI1 = DVI-I (DVI-A and DVI-I-D)

DVI2= DVI-D (DVI-2D)

This menu allows the selection of 1 of these 3 inputs.

```
<  M o n i t o r  >  
I n p u t :   D V I _ D ( 1 )
```

3) MONITOR BRIGHTNESS

Brightness level (0 – 100).

```
<  M o n i t o r  >  
B r i g h t :   ( 0 5 0 )
```

4) MONITOR CONTRAST

Contrast level (0 – 100).

```
<  M o n i t o r  >  
C o n t r a s t :   ( 0 5 0 )
```

ISD MENU

5) MONITOR BACKLIGHT

Backlight level (0 – 100).

```
< M o n i t o r >
B k . l i g h t : ( 0 5 0 )
```

6) POSITION

It is a diagnostic option that informs about the position of the device.

```
< M o n i t o r >
P o s i t i o n : ( 0 2 3 )
```

7) SENSORS INFORMATION

It is a diagnostic option that informs about the internal state of the sensors.

```
S 1 | 2 | 3 | 4 | 5 | 6 | 7 | 8
I 0 | 1 | 1 | 1 | 1 | 1 | 1 | 1
```

8) AHnet - INFORMATION

This menu is useful for programming and diagnose.

It provides information about the AHnet command that has been received by the device.

Example: AHnet = 0 (FA) 1 (01) 2 (01) 3 (01) 4 (00)

```
A H n e t : 0 ( F A ) 1 ( 0 1 )
2 ( 0 1 ) 3 ( 0 1 ) 4 ( 0 0 )
```

ISD MENU

9) UNIT OPENS

It is a diagnostic option that provides historical data.

It is very useful to analyze how the device has been used during its lifecycle and it provides information about how many movements the device has done.

```
< U n i t   O p e n i n g s   >  
T i m e s : ( 0 0 0 0 0 )
```

10) UNIT STOPS

It is a diagnostic option that provides historical data. It is very useful to analyze how the device has been used during its lifecycle.

It provides information about the number of times that the device has been protected and made emergency stops.

```
< U n i t       S T O P s   >  
T i m e s : ( 0 0 0 0 0 )
```

11) SERIAL NUMBER

Provides the device's serial number.

```
< S e r i a l   N u m b e r   >  
S . N . : 0 1 2 3 4 5 6 7 8 9
```

The serial number can also be obtained via AHnet and AHlink.

12) MONITOR DOWN

Only use this function as per manufacturer advice.

```
< M o n i t o r   D O W N   >  
O n l y   f o r   S E R V I C E
```

ISD MENU

13) AUTO ADJUST

Auto Mechanical Movement Calibration (AH-AMMC).

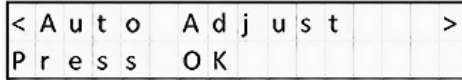

Protocol activation: the device will make a consecutive movements series that must not be interrupted. The system will calibrate the speed and protection thresholds.

14) AHLINK

Activates AHLINK.



FIRMWARE UPDATE

To update the FW version.

To start the update, connect a PC with the APP AH_FW (Device Setting Tool) to the device through the USB port.

Proceed with the following steps:

- Unplug the PSU
- Wait for 1 minute
- Press and hold the "OK" button
- Plug in the PSU
- A message will appear on the LCD screen when the connection is ready
- Start updating the AH_FW

How are you doing? Easy, right?

Now you just have to start enjoying your device 😊

INPUT CONNECTORS

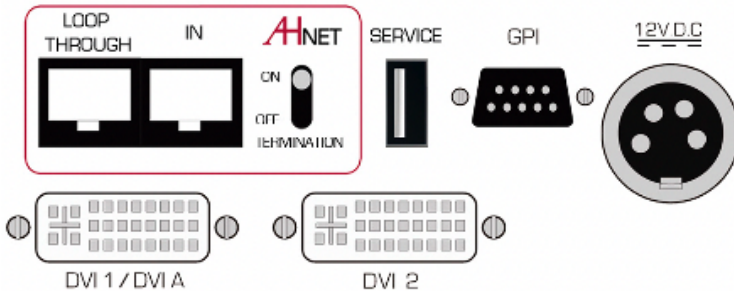

12V D.C.  : Power supply input connector. XLR-4 connector.

- 1,2: Ground
- 3,4: 12Vdc

GPI: Monitor external contact close control. SubD9 female.

1. GPI1 +
 2. GPI1 -
 3. GPI2 +
 4. GPI2 -
 5. GPI3 -
 6. GPI3 +
 7. N.C.
 8. +12Vdc (600mA max.)
 9. Ground:
- Use GPI1 (1:12Vdc, 2: Ground) to open the monitor
 - Use GPI3 (6:12Vdc, 5: Ground) to close the monitor

Termination: Activate (ON) the termination. Only on the last unit of the RS422 bus.

AHnet: RJ45 CAT6 connector for addressable RS422 control. There is a loop through connector to use as signal RS422 output. Up to 30 monitors can be connected on the same RS422 bus.

Service: Used for firmware's upgrade.

DVI 1 / DVI A: DVI-I input signal. Connect a DVI (digital) input signal and select DVI 1 on the OSD monitor menu. Use a DVI to VGA adaptor to connect an ARGB (analogue) input signal and select DVI-A on the OSD monitor menu.

DVI 2: DVI-D input signal. Connect a DVI (digital) input signal and select DVI 2 on the OSD monitor menu. Use high quality DVI cables with 2m maximum length.

AHnet PROTOCOL

Communications protocol

COMMUNICATION	RS422
CONNECTION	RJ45
WIRING	CAT-6

Speed and configuration

BAUD RATE	38400
DATA BITS	8
PARITY	NONE
STOP BITS	1

Wiring Diagram

- 1. Data TX +
- 2. Data TX -
- 3. Data RX +
- 4. NC
- 5. NC
- 6. Data RX -
- 7. NC
- 8. NC



RJ-45

Connection

PINS 1 & 2	The units respond
PINS 3 & 6	The units receive instructions

Protocol to control the monitor by addressable RS422 bus.
You can connect up to 30 monitors on the same RS422 bus.
You can use an AH ERT interface, to control the RS422 bus.
The units should have a set address and the address must start by 1.
Maximum cable length between ends: 500 m/1 640 ft.

AHnet PROTOCOL

AHnet protocol

Uses 5 bytes communication:

BYTE 0	START BYTE
BYTE 1	ADDRESS BYTE
BYTE 2	COMMAND BYTE
BYTE 3	VALUE 1
BYTE 4	VALUE 2

Commands

COMMAND	DESCRIPTION	RESPONSE
FA XX 01 01 00	GO UP	FB XX 01 01 00
FA XX 01 00 00	GO DOWN	FB XX 01 00 00
FA XX 02 01 00	SCREEN ON	FB XX 02 01 00
FA XX 02 00 00	SCREEN OFF	FB XX 02 00 00
FA XX 03 01 00	DVI-A SELECTION	FB XX 03 01 00
FA XX 03 00 00	DVI-1 SELECTION	FB XX 03 00 00
FA XX 03 03 00	DVI-2 SELECTION	FB XX 03 03 00
FA XX 04 01 00	BUTTON LOCK	FB XX 04 01 00
FA XX 04 00 00	BUTTON UNLOCK	FB XX 04 00 00
FA XX 14 00 00	INQUIRY CONTROL BYTE	FB XX 14 CB1 CB2

XX Number of the monitor address. Up to 30 monitors for each RS422 BUS

CB1 Response in 8 bites of the monitor status

CB2 Response in 8 bites of the monitor status

AHnet PROTOCOL

CB1

BITE	7	6	5	4	3	2	1	0
CLOSED			1	1	0	1		
OPENED			0	1	0	1		
SCREEN ON							1	
SCREEN OFF							0	
DVI-A	0	0						
DVI 1-D	1	1						
DVI 2-D	1	0						
PROTECTION STOP								1
MONITOR OK								0

CB2

BITE	7	6	5	4	3	2	1	0
BUTTON LOCK								1
BUTTON UNLOCK								0

AHnet PROTOCOL

Picture Commands

COMMAND	DESCRIPTION	RESPONSE
FA XX 15 00 00	ASK FOR BACKLIGHT LEVEL	FB XX 15 00 ZZ
FA XX 16 00 00	ASK FOR CONTRAST LEVEL	FB XX 16 00 ZZ
FA XX 17 00 00	ASK FOR BRIGHTNESS LEVEL	FB XX 17 00 ZZ

XX Number of the monitor address.
Up to 30 monitors for each RS422 BUS

ZZ Level of the function selected (00 – 99 Dec)

COMMAND	DESCRIPTION	RESPONSE
FA XX 15 01 ZZ	SET BACKLIGHT LEVEL	FB XX 15 01 ZZ
FA XX 16 01 ZZ	SET CONTRAST LEVEL	FB XX 16 01 ZZ
FA XX 17 01 ZZ	SET BRIGHTNESS LEVEL	FB XX 17 01 ZZ

XX Number of the monitor address.
Up to 30 monitors for each RS422 BUS

ZZ Level of the function selected (00 – 99 Dec)

To send an order to all the monitors, you must use the address:
249 Dec. (Byte1)
F9 Hex. (Byte1)

In this case, the units do not send a reply.

VIDEO SIGNALS

RESOLUTION	Horizontal freq (KHz)	Vertical freq (Hz)	Scanning type
800x600@60Hz	37.879	60.317	Progressive
800x600@72Hz	48.077	72.188	Progressive
800x600@75Hz	46.875	75.000	Progressive
1024x768@60Hz	48.363	60.005	Progressive
1024x768@70Hz	56.476	70.070	Progressive
1024x768@75Hz	60.023	75.030	Progressive
1280x720@60Hz	44.772	59.855	Progressive
1360x768@60Hz	47.720	59.799	Progressive
1280x1024@60Hz	63.981	60.020	Progressive
1600x1200@60Hz	75.000	60.000	Progressive
1680x1050@60Hz	64.742	59.946	Progressive
1920x1080@60Hz	67.500	60.000	Progressive

AHlink

AHlink is used to control and set-up the unit.

By default, the AHlink wireless signal is deactivated. To activate it, please press and hold the Open and Close buttons simultaneously on the cover plate for 5 seconds.

You can also activate the AHlink signal with the LCD (Interactive Setup Display) located under the monitor. Press the Down key near the LCD (Interactive Setup Display), until the "<AHlink>" option appears. Press the OK button to activate the AHlink signal on the unit. When the AHlink signal is activated, the sound of 5 beeps will indicate that the AHlink signal is active on the unit.

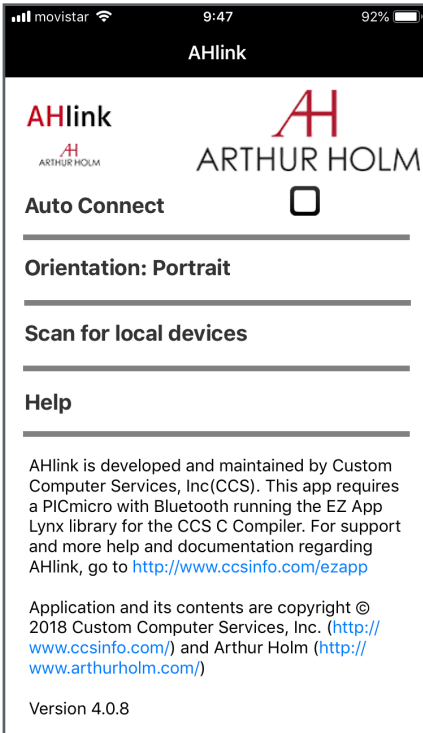

The wireless AHlink signal automatically deactivates when there is no device connected during more than 2 minutes. When the AHlink deactivates, you will hear a long Beep sound.

To control and set up your AH product with AHLink, please download it from the App Store (IOS system) or from Google Play (Android system) and execute it in your handled device.

It is recommended on to select *Auto Connect* and select *Portrait* on *Orientation*. To connect it, select *Scan for local devices*.

AHlink

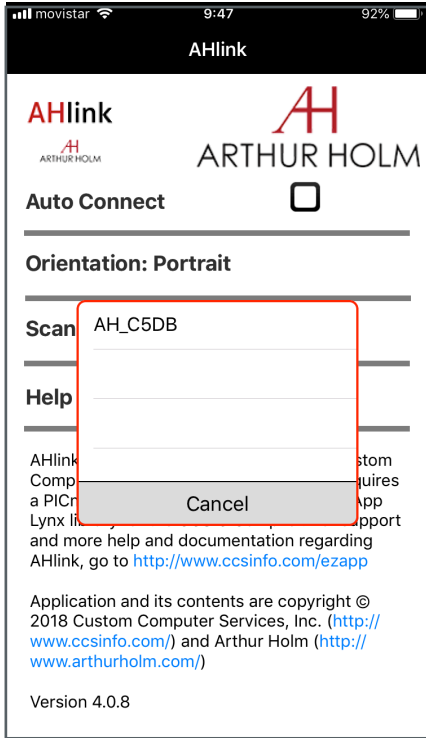

After selecting the AH device, the first page will upload on your screen. This page is used for the basic installation setup.

If your AH device does not appear on the screen, the AHLink signal might no longer be active.

The AHLink name always begins with the characters "AH" followed by the four last MAC AHLink address. You must select the AH device.

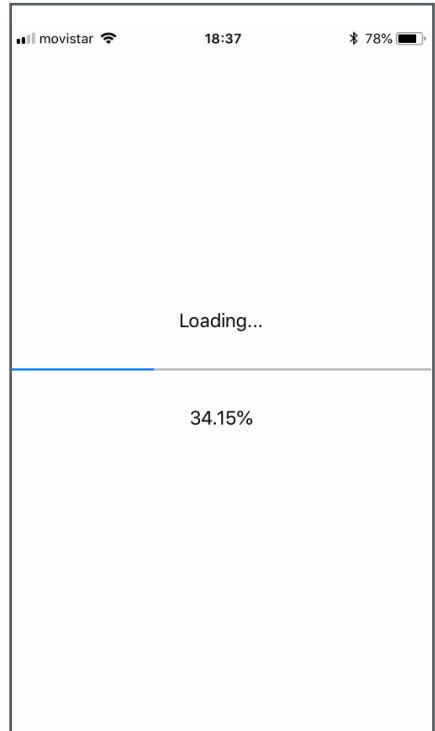

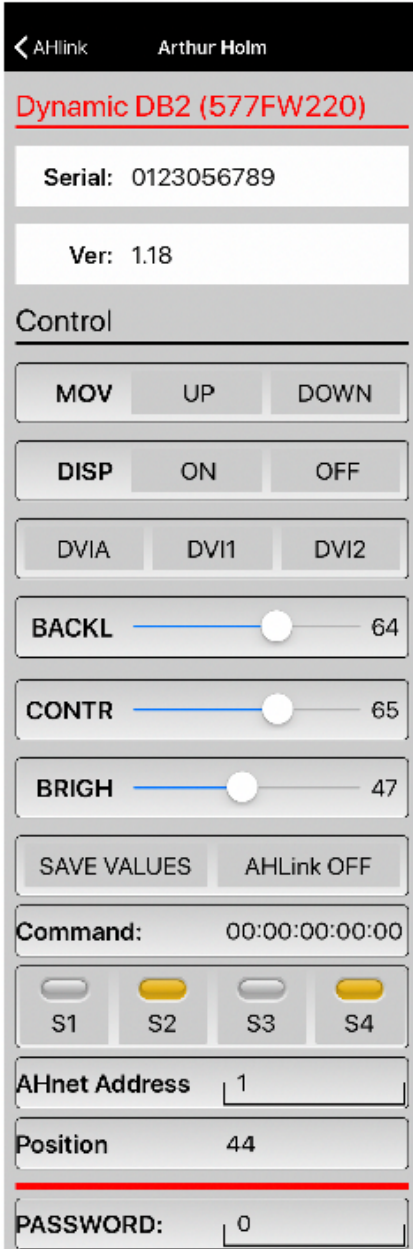

SERIAL

Serial number of the unit

VER

Firmware version

MOV

Controls the Up and Down monitor movements

DISP: Turns the display ON or OFF

DVIA, DVI1, DVI2: Input source selection

BACKL: Backlight adjustments

CONTR: Contrast adjustments

BRIGHT: Brightness adjustments

SAVE VALUES: Memorises the backlight, contrast and brightness values

AHLINK OFF: Turns off the AHlink signal

COMMAND: Information of the last AHnet command received from RS422 port

SENSORS: Indicates sensor status.

S1 indicates the screen up position

S2 Indicates the 110° tilt screen position

S3 Indicates the 90° tilt screen position

AHNET ADDRESS: AH address settings

POSITION: Screen position

PASSWORD: Access to the factory's settings

INFORMATION ON DISPOSAL FOR USERS OF WASTE ELECTRICAL & ELECTRONIC EQUIPMENT



This symbol on the products and/or accompanying documents means that used electrical and electronic products should not be mixed with general household waste.

For proper treatment, recovery and recycling, please take these products to the designated collection points, where they will be accepted on a free of charge basis. Alternatively, in some countries, you may be able to return your products to your local retailer upon the purchase of an equivalent new product.

Disposing of this product correctly will help save valuable resources and prevent any potential negative effects on human health and the environment, which could otherwise arise from inappropriate waste handling. Please contact your local authority for further details of your nearest designated collection point.

Penalties may be applicable for incorrect disposal of this waste, in accordance with national legislation.

For business users in the European Union

If you wish to discard electrical and electronic equipment, please contact your dealer or supplier for further information.

Information on disposal in countries outside the European Union

This symbol is only valid in the European Union. If you wish to discard this product, please contact your local authorities or dealer and ask for the correct method of disposal.

WARRANTY TERMS AND CONDITIONS

Albiral Display Solutions warrants this product against manufacturing defects and workmanship for a period of five (5) years from the date of purchase, subject to the conditions below.

1. Mechanical parts: The engine and the product's mechanical parts are warranted against manufacturing defects and workmanship for a period of five (5) years from the date of purchase.
2. LCD panel, inverter, controller, electrical, electronic boards, accessories and power supply are warranted against manufacturing defects and workmanship for a period of two (2) years from the date of purchase.
3. LCD panels that present more than 3 defective pixels (15-19") and more than 4 defective pixels (20-24") will be replaced under warranty.
4. Labour costs: Albiral Display Solutions covers the labour costs to replace any defective parts during the validity of this warranty.
5. Transport costs:
 - 5.1. In the case that a manufacturing defect occurs within 90 days after the purchase date, both freight and insurance costs will be paid by Albiral Display Solutions.

Although Albiral Display Solutions S.L. pays for freight and insurance costs, Albiral Displays Solutions will not be responsible for any damages caused by the transportation of the goods if the customer does not inform in writing when receiving the goods.

- 5.2. After 90 days of the purchase date, the beneficiary of the warranty will pay both freight and insurance costs.

Albiral Display Solutions S.L. will not be responsible for any damages caused by transportation, when this one is paid by the customer.

6. This warranty does not cover the labour costs of handling, diagnose, removal, replacement, reinstall and/or program any product.

WARRANTY TERMS AND CONDITIONS

7. This warranty does not apply if the fault has been caused by misuse, improper handling, electrical or mechanical abuse, abnormal operation conditions, non-authorized modifications, and inadequate transportation or as a result of atmospheric phenomenon.
8. The warranty is not valid if people other than authorized Service Centre have handled the product and if the product has been manipulated or warranty seals are removed or manipulated.
9. The beneficiary of the warranty will have to return the product with the original packaging to warranty there are no damages during transportation.
10. The warranty is not valid if the beneficiary of the warranty does not include an RMA form and a copy of the purchasing invoice.

Please note that laws vary from country to country, and the same provisions of this warranty may not apply to you.

If you have any doubts concerning the terms of this warranty, please contact:

business@albiral.com

+34 938 502 376

Copyright ©

Nov. 2020. All rights reserved

Albiral Display Solutions SL.

Registered trademarks: Albiral, Arthur Holm



ARTHUR HOLM

**Albiral
Display
Solutions**

Fàtima 25, Sant Hipòlit de Voltregà
08512 Barcelona – Spain
tel: +34 93 850 23 76 / 23 83
fax: +34 93 850 25 50 / 23 72
web: www.arthurholm.com
e-mail: marketing@arthurholm.com

Patents

MU17180ES00	P27178RUPC
MU17301ES00	P27178USPC
MU17322ES00	P27284DEEP
MU17413ES00	P27284EPPC
MU17445ES00	P27284ESEP
MU17854ES00	P27284GBEP
MU17868DEPC	P27284RUPC
MU17868RUPC	P27284USPC
P24821DEEP	P27715ESEP
P24821ESEP	P28089DEEP
P24821GBEP	P28089ESEP
P24821USPC	P28089ITEP
P27178DEEP	P28089USPC
P27178EPDV01	P28090EP00
P27178EPPC	P31160ESES
P27178ESEP	P31160PCES