

Professional lift system for microphones, to be integrated into meeting and conference room tables

Ref. AHDTL M v1.1 UC

TABLE CUT OUT

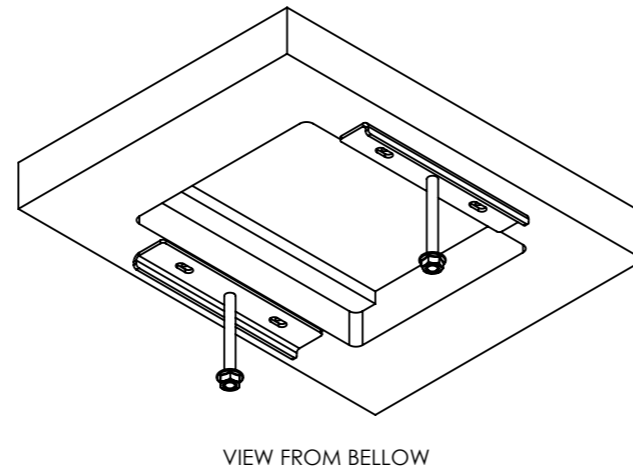
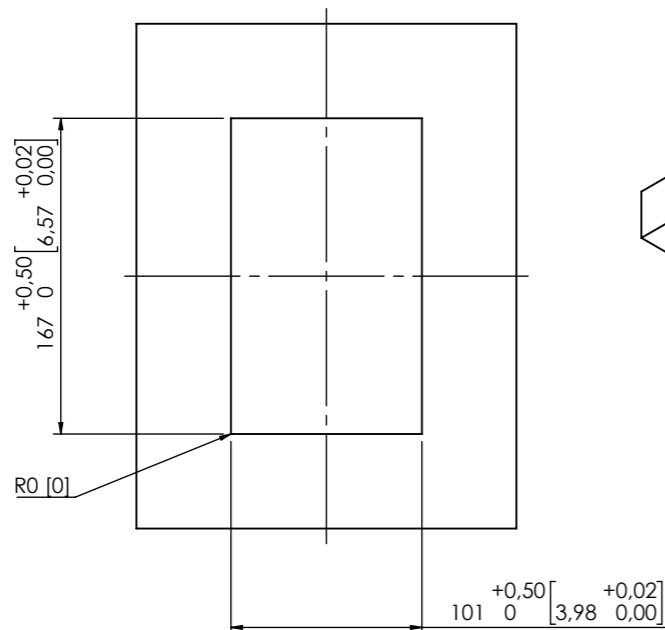
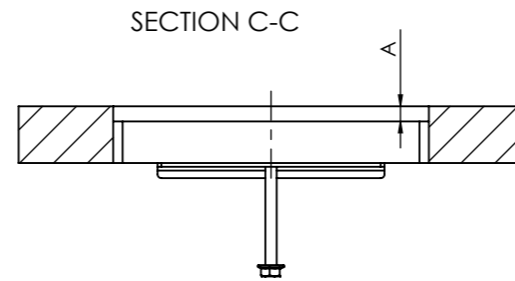
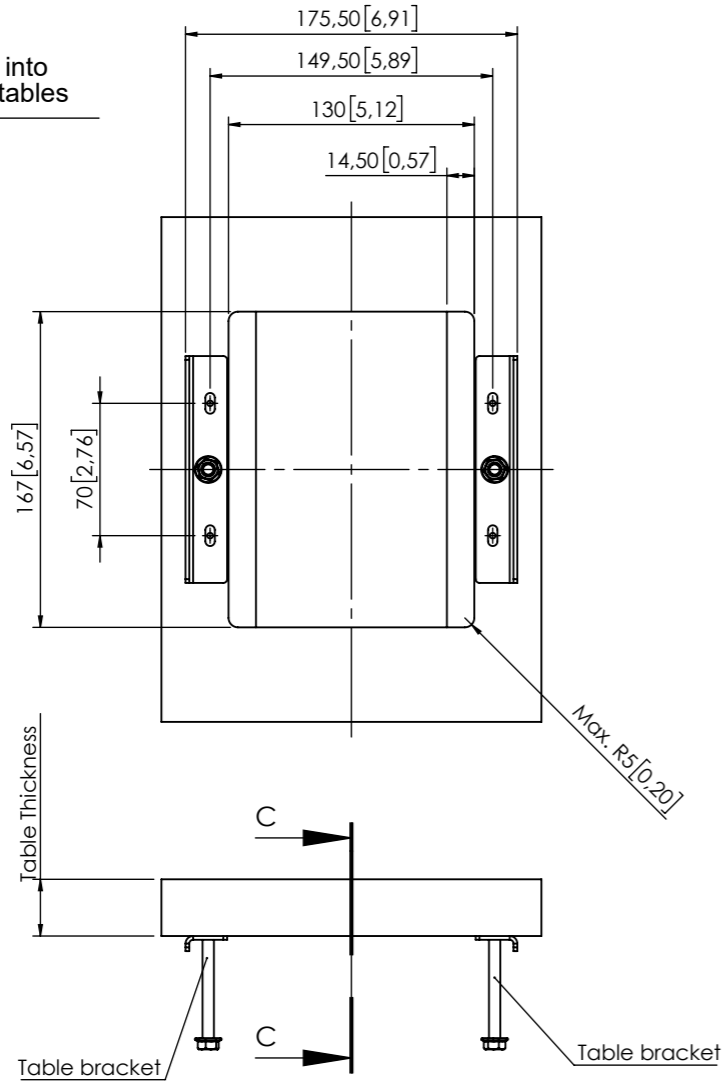

VENEER LID DIMENSIONS

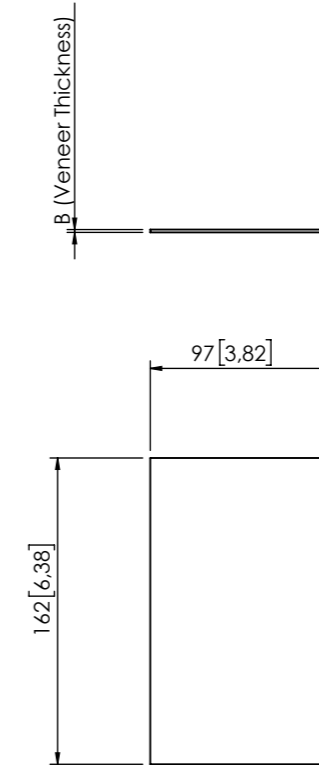

- Table thickness: Min. 12mm [0.47] Max. 40mm [1.57]
- B (Maximum Veneer thickness): 4mm [0.157]
B + (Glue or tape): 4.2mm [0.16]
- Maximum A dimension on the table (including table veneer):
A = 7,5mm [0.29] + B (Veneer thickness) ;
Ex: Having a lid Veneer thickness of 2mm [0.08]
A dimension will be 7,5+2 = 9,5mm [0.37]