



User Guide



DynamicTalk

Universal motorised system for gooseneck microphones

Technology Serving Design

Danish craftsmanship
Mediterranean soul

ARTHUR HOLM

WELCOME

Thank you for purchasing an ARTHUR HOLM product.

Please, read this installation and operating instructions carefully and keep them in a safe place for future reference.

We remain at your entire disposal if you have any suggestions.

Henrik Holm

General Manager

hholm@albiral.com

ABOUT US

The Company

Arthur Holm has its origins in the Danish furniture designer Jorgen Alex Jensen, who was active during the sixties and the seventies. His design inspiration and his concept of ergonomics have been continued by his family, who is the design force behind Arthur Holm product range. The result of combining Scandinavian design tradition with Mediterranean creativity, flexibility and emotion is a wide product range built on more than 25 years of craftsmanship.

Arthur Holm offers a professional product range where tomorrow's technology is shaped into valued materials with design flexibility and customisation, specially created to enhance communication in reception, collaboration, conference and meeting areas.

The art of customisation

Arthur Holm offers a range of ingenious products whose designs are based on quality materials and the latest technology. Products which endow meeting and conference rooms with silent, ergonomic, innovative and aesthetic solutions that integrate into the furniture, hang from the walls as works of art or are used as interactive points of information.

The world of Arthur Holm

Arthur Holm offers a selection of unique, elegant, versatile, flexible and ergonomic products that are being used in meeting and conference rooms, reception areas, huddle rooms, control rooms, auditoriums and public zones of leading companies throughout the world.

The numbers speak for themselves! We currently own 33 product patents, have presence in over 45 countries with products and solutions in more than 25,000 installations.

It will be our pleasure to work with you, designing your unique and personalised environment. Our broadcast electronic engineers will provide the latest technology while our design team will offer you the most exclusive appearance.

Our team puts its heart, passion and pride in all our designs.

TABLE OF CONTENTS

REGULATIONS AND SECURITY	5
SAFETY INSTRUCTIONS	5
SYSTEM DESCRIPTION	8
INSTALLATION INSTRUCTIONS	11
POWER AND CONTROLS	12
CONTROLS	14
DYNAMICTALK HANDLING	16
AHnet PROTOCOLS	17
AHlink	19
INFORMATION ON DISPOSAL	23
WARRANTY TERMS AND CONDITIONS	24

REGULATIONS AND SECURITY



ATTENTION: Do not disassemble or modify the device in any way. This symbol warns of the presence of dangerous un-insulated voltages inside some of the components, of sufficient magnitude to expose people to risk of electronic shock.



This symbol draws attention to important use and maintenance instructions in the manual that accompanies the unit.



This symbol indicates that the equipment conforms to the norms established by the European Community.



This symbol indicates D.C. current.

SAFETY INSTRUCTIONS

Plugs

- Do not dismantle any part of the monitor power connector.
- Disconnect the power plug from the AC outlet when the monitor is not going to be used for an indefinite period of time.

Power and extensions cords

- Use the appropriate power cord with the correct plug type.
- Do not overload wall outlets or power cords.
- Make sure the total ampere passed through a extension cord does not exceed the maximum allowed by the cable used.
- Do not place anything on the power cord.
- Do not locate this product where a person may walk or trip over the cord.

SAFETY INSTRUCTIONS



Wiring connected to hazardous voltage requires installation by qualified personnel or the use of ready-made flexible cables.



For your security, your equipment must be connected to an electrical outlet with grounding connection protection. Since the plug is used to disconnect the device, the operating electrical outlet must be in an easily accessible place.



Moving parts:

Keep body parts out of the motion path.

Environment

- Install the equipment on an elevated, flat surface.
- Cannot be installed at a height greater than two meters.
- Install the equipment in a ventilated area.
- Avoid exposing the equipment to:
 - Rain or water
 - Excessive heat, cold or humidity
 - Area exposed to direct sunlight
 - Dirty areas
 - Equipment generating strong magnetic fields
- Avoid placing open containers of liquid, near the equipment.
- Keep a minimum distance of 30 mm in order to have good ventilation.
- Never place above the device any sources of flames such as lighted candles, etc.
- If you are using the device in extreme weather conditions and/or tropical climates, the equipment should be installed in a room which ensures a reasonable level of temperature and humidity.
- To prevent damage, the equipment must be firmly anchored to the surface, as shown in the installation instructions.

SAFETY INSTRUCTIONS

This equipment has been tested and found to comply with the limits for a Class B digital device, pursuant to part 15 of the FCC Rules. These limits are designed to provide reasonable protection against harmful interference in a residential installation. This equipment generates, uses and can radiate radio frequency energy, and if not installed and used in accordance with the instructions, may cause harmful interference to radio communications. However, there is no guarantee that interference will not occur in a particular installation. If this equipment does cause harmful interference to radio or television reception, which can be determined by turning the equipment off and on, the user is encouraged to try to correct the interference by one or more of the following measures:

- Reorient or relocate the receiving antenna
- Increase the separation between the equipment and receiver
- Connect the equipment into an outlet on a circuit different from that to which the receiver is connected
- Consult the dealer or an experienced AV technician for help

SYSTEM DESCRIPTION

General

DynamicTalk is an elegant retractable system for gooseneck microphones with exclusive features. It not only makes the microphone disappear within the desk surface but it also provides a pleasant light to indicate its status. Due to its protective patented lighting ring, the microphones can be safely stored, protected, making meeting and conference spaces more flexible and versatile.

DynamicTalk provides two different working modes: PA and Conference. When in PA mode, a push button placed on the stainless steel cover plate activates or de-activates the microphone and the LED ring will indicate the status by changing colour from red to green. This microphone lifting system automatically silences the microphone when retracting whereas in conference mode the microphone remains active and can be controlled via GPI and GPO.

Highlights

- Universal microphone lift system for gooseneck XLR 3 pin microphones
- Stainless steel cover plate with 3 buttons
- Patented 360° LED lighting ring to indicate microphone status
- AH-AMMC Auto Mechanical Movement Calibration
- PA and Conference working modes
- Wireless connectivity for setup and control

Box Contents

Before the installation of your retractable monitor, please check the contents of the shipping box, it must contain the following items:

- DynamicTalk
- Power cord
- Power supply 100-240Vac, 50-60Hz. Output 12V
- User Manual

Important note: This device can only work with the power supply included in the shipping box. This power supply can not be replaced by any other rather than the original one.

SYSTEM DESCRIPTION

Available Models

MODEL	DESCRIPTION
AHDTLS	Professional retractable system for 3 pin XLR gooseneck microphones with a maximum length of 400 mm (microphone not included). The cover plate is made of brushed stainless steel and provides a rounded microphone coverlid and 3 operation buttons to open/close, mute/unmute and a free GPO button. The lift system includes a translucent plastic rounded ring to centre the microphone during its rise and retract movement from a position hidden below the cover to a top position projected through the cover, avoiding the microphone from touching the cover plate, damaging or blocking when retracting. Compatible with AHlink: a wireless app that allows the system to be adjusted to the exact microphone length, facilitates the unit's serial number, allows the activation and deactivation of the RS- 422 termination and allows to change the working mode from PA to Conference.
AHDTLM	Professional retractable system for 3 pin XLR gooseneck microphones with a maximum length of 500 mm (microphone not included). The cover plate is made of brushed stainless steel and provides a rounded microphone coverlid and 3 operation buttons to open/close, mute/unmute and a free GPO button. The lift system includes a translucent plastic rounded ring to centre the microphone during its rise and retract movement from a position hidden below the cover to a top position projected through the cover, avoiding the microphone from touching the cover plate, damaging or blocking when retracting. Compatible with AHlink: a wireless app that allows the system to be adjusted to the exact microphone length, facilitates the unit's serial number, allows the activation and deactivation of the RS- 422 termination and allows to change the working mode from PA to Conference.
AHDTLL	Professional retractable system for 3 pin XLR gooseneck microphones with a maximum length of 600 mm (microphone not included). The cover plate is made of brushed stainless steel and provides a rounded microphone coverlid and 3 operation buttons to open/close, mute/unmute and a free GPO button. The lift system includes a translucent plastic rounded ring to centre the microphone during its rise and retract movement from a position hidden below the cover to a top position projected through the cover, avoiding the microphone from touching the cover plate, damaging or blocking when retracting. Compatible with AHlink: a wireless app that allows the system to be adjusted to the exact microphone length, facilitates the unit's serial number, allows the activation and deactivation of the RS- 422 termination and allows to change the working mode from PA to Conference.

SYSTEM DESCRIPTION

Options

AHDTLS	AHDTLM	AHDTLL
ACP (Min. 5 units) Aluminium cover plate	ACP (Min. 5 units) Aluminium cover plate	ACP (Min. 5 units) Aluminium cover plate
CP (Min.5 units) Painted	CP (Min.5 units) Painted	CP (Min.5 units) Painted
CCUSBC USB passthrough	CCUSBC USB passthrough	CCUSBC USB passthrough
CC2USBC 2 USB passthroughs	CC2USBC 2 USB passthroughs	CC2USBC 2 USB passthroughs
CCUSBPower USB power	CCUSBPower USB power	CCUSBPower USB power

INSTALLATION INSTRUCTIONS

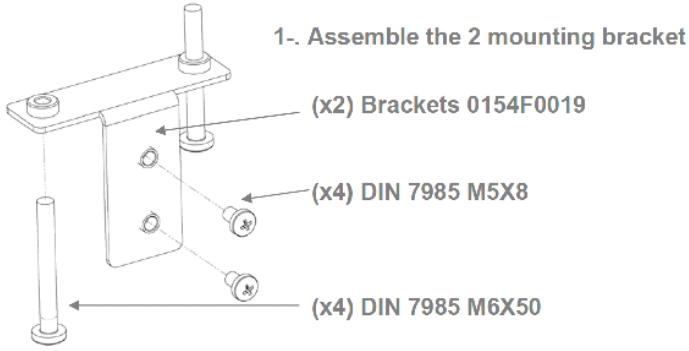

2- With the DynamicTalk inserted into the table attached the brackets in each side

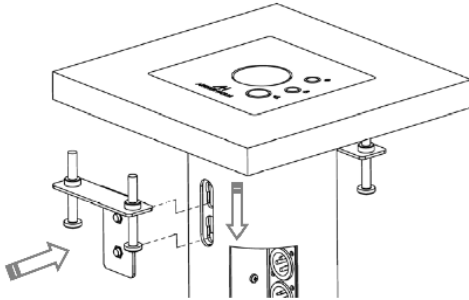

3- Tighten the four M6x50 screws until they touch the table and DynamicTalk is fixed

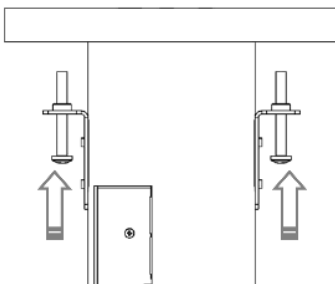

POWER AND CONTROL

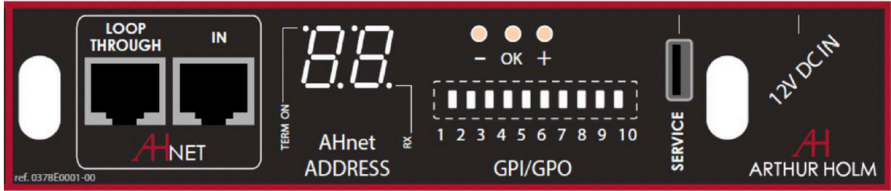

AHnet: RJ45 CAT5 connector for addressable RS422 control. There is a loop through connector to use as signal RS422 output. You can connect up to 30 devices on the same RS422 bus.

AHnet ADDRESS: Shows the AHnet Address configured on this unit.

TERM ON: Brighting when the RS422 bus termination is active. Active only the RS422 bus termination on the last unit of the bus.

RX: Illuminates when the unit receives a RS422 AHnet command.

OSD – OK +

- Changing AHnet Address. Press OK button. Change the AHnet number address using + and – keys, and press OK to save the new address.

- RS422 bus termination. Press + key to activate the RS422 termination. Press – key to deactivate the RS422 termination.

INPUT CONNECTORS

GPI/GPO external contact close connector:

1. GND
2. Command microphone UP connecting to GND. Connecting to GND more than 2 seconds, activates the AHLINK signal (5 beeps sounds when the AHLINK signal is activated)
3. Command microphone DOWN connecting to GND
- Use a pulse signal to RISE and LOWER the microphone
4. Red LED ring brights connecting to GND (only in conference mode)
5. Green LED ring brights connecting to GND (only in conference mode)
6. GND
- 7, 8 GPO1. Contact close of the central button located on cover plate
- 9, 10 GPO2. Contact close of the talk button located on cover plate

 **12V D.C.:** Power supply input connector. XLR-4 connector:

1,2: Ground

3,4: 12Vdc

SERVICE: Used for firmware upgrade.

CONTROLS

Monitor movement controls

On the upper cover plate, there are three buttons to control the functions and to external control other devices (GPO)



1. UP/DOWN:

Controls the elevation and retraction of the microphone lift. Press this button during 5 seconds to activate AHlink (5 beeps sounds when AHlink is activated).

2. Customised:

The central push button, is used to control external devices. The contact close button (GPO) is present on GPO connector to external control other devices. Contact close of the GPO pins 7, 8 while pressing this button.

CONTROLS

3. TALK or GPO:

The third push button has two different functions:

- PA mode: In PA mode this button is used as MUTE function. Press the button once and the LED ring will appear in red indicating that the MUTE function is deactivated and it's ready for the user to talk to the audience. Press the button again to activate the MUTE function and silent the microphone, which will be indicated by the green LED ring. The contact close button (GPO) is present on GPO connector to external control other devices. Contact close of the GPO pins 9, 10 while pressing this button.
- Conference mode: In Conference mode the microphone is controlled by the external conference system. This button then, has no function and the contact close of the push button is present on the GPO control connector. The contact close button (GPO) is present on GPO connector to external control other devices. Contact close of the GPO pins 9, 10 while pressing this button.

4. Dynamic LED Ring:

The system has a LED Ring to indicate the status of the microphone: RED indicates that the MUTE function is deactivated and GREEN indicates that the MUTE is activated. When the equipment is configured to work on Conference mode, the LED Ring is externally controlled by GPI on the GPI external control connector.

PRODUCT HANDLING

Please follow the figure below for a correct product usage of the DynamicTalk microphones.

To avoid any product malfunctions, do not attempt to bend the microphone to the incorrect angle or outside the microphone's working area, as indicated on the picture below.

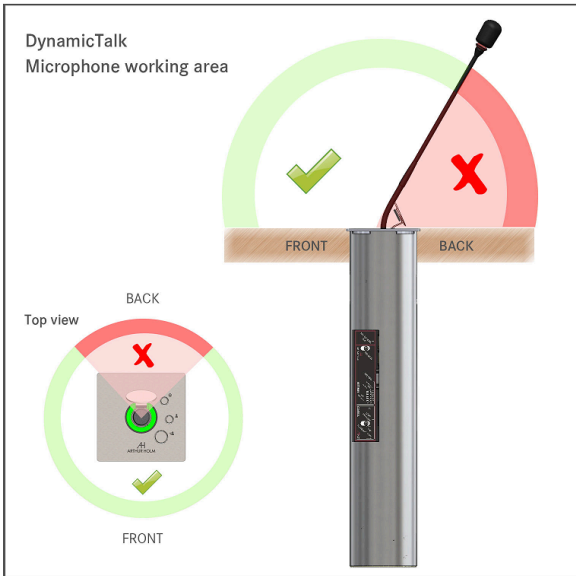

AHNET PROTOCOL

Communications protocol

COMMUNICATION CONNECTION	RS422
WIRING	RJ45
	CAT-6

Speed and configuration

BAUD RATE	38400
DATA BITS	8
PARITY	NONE
STOP BITS	1

Wiring Diagram

1. Data TX +
2. Data TX -
3. Data RX +
4. NC
5. NC
6. Data RX
7. NC
8. NC



RJ-45

Connection

- PINS 1 & 2 The units respond
PINS 3 & 6 The units receive instructions

Protocol to control the unit by addressable RS422 bus.
You can connect up to 30 devices on the same RS422 bus.
You can use an AH Interface Ethernet, to control the RS422 bus.
The units should have a set address and the address must start by 1.
Maximum cable length between ends, 500 m/1640 ft.

AHnet protocol

Using 5 bytes communication:

BYTE 0	START BYTE
BYTE 1	ADDRESS BYTE
BYTE 2	COMMAND BYTE
BYTE 3	VALUE 1
BYTE 4	VALUE 2

AHNET PROTOCOL

Commands

COMMAND	DESCRIPTION	RESPONSE
FA XX 01 01 00	GO UP	FB XX 01 01 00
FA XX 01 00 00	GO DOWN	FB XX 01 00 00
FA XX 02 01 00	MUTE ON (Only in PA mode)	FB XX 02 01 00
FA XX 02 00 00	MUTE OFF (Only in PA mode)	FB XX 02 00 00
FA XX 04 00 00	BUTTON LOCK	FB XX 04 00 00
FA XX 04 01 00	BUTTON UNLOCK	FB XX 04 01 00
FA XX 14 00 00	INQUIRY CONTROL BYTE	FB XX 14 CB1 CB2

- XX Number of the DynamicTalk address. Up to 30 units can be connected for each RS422 BUS
- CB1 Response in 8 bits of the device status
- CB2 Not implemented

CB1

BITE 0	TOP POSITION
BITE 1	DOWN POSITION
BITE 2	(1) MUTE ON
BITE 3	(1) BUTTON LOCK
BITE 4	
BITE 5	
BITE 6	
BITE 7	(1) FAILURE IN THE SYSTEM

To send an order to all the devices, you must use the address:
F7 Hex. (Byte1)

In this case, the units do not respond
Use shielded (FTP) RJ45 cables for RS422 BUS.

AHLINK

AHlink is used to control and set up the unit.

By default, the AHlink signal on the unit is deactivated. To activate the AHlink signal, press for 5 seconds the external Up and Down screen buttons located on the cover plate, or press for 5 seconds the UP and Down contact close on the GPI connector. You can also activate the AHlink signal with the LCD located under the monitor. Press the Down key near the LCD, until the "<AHlink>" option appears. Press the OK button to activate the AHlink signal on the unit. When the AHlink signal is activated, the sound of 5 beeps will indicate that the AHlink signal is active on the unit.

The unit automatically deactivates the AHlink signal if there is no device (mobile or tablet) connected for more than 2 minutes. The user can also deactivate the AHlink signal using the APP on mobile or tablet. When the AHlink signal is deactivated, the sound of long beep will indicate that the AHlink is not longer available on the unit.

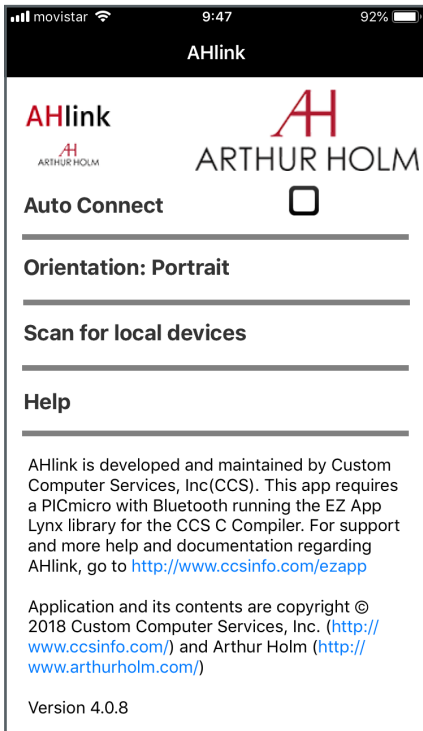

To control and set-up the unit using AHlink, download AHlink App from the App Store (IOS system) or from Google Play (Android system). The App is free. Execute the AHlink App on your mobile phone.

On the AHlink App options, it is recommended not to select *Auto Connect* and select *Portrait* on *Orientation*. To connect to the device, select *Scan for local devices*.

AHLINK

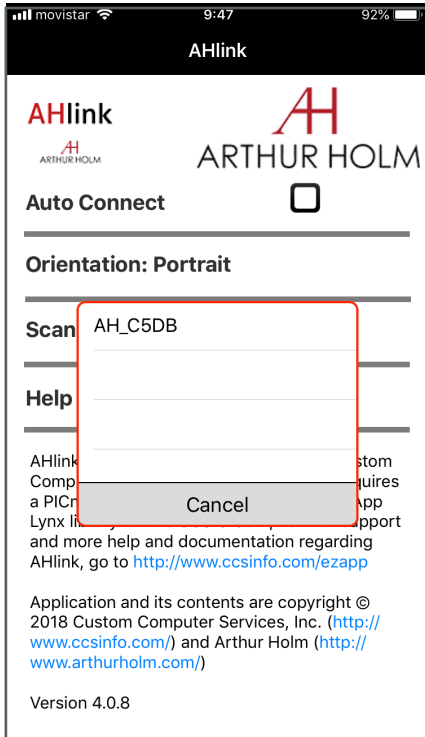

When selecting the device, the first page will upload on the mobile phone. This page is used to check the device and for basic diagnostic during the installation process.

If the device does not appear on the window, the AHLINK signal is not active. To activate, press for 5 seconds the Up and Down button located on cover plate, or contact close to GND GPI pin2 for 5 seconds. You can hear 5 beeps indicating that the AHLINK signal is activated.

The AHLINK name always begins with AH characters and the fourth last MAC AHLINK address. Select the device to control and set up the unit.

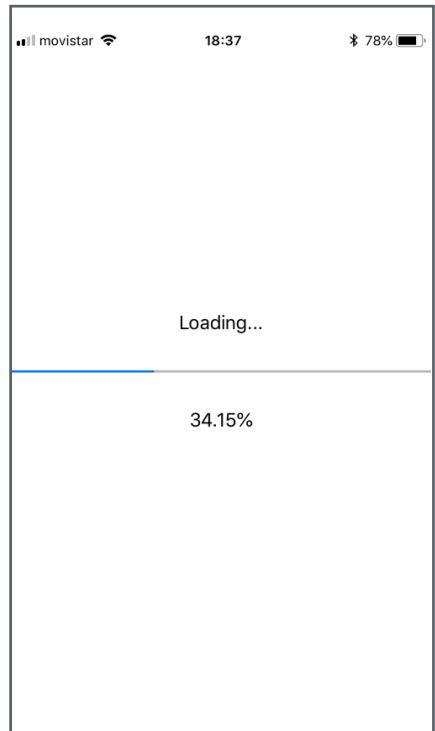



FIRST LINE, SHOWS THE MODEL NAME OF THE DEVICE

SERIAL
Serial number of the unit

VER
Firmware version

BEEP: A Beep will sound while pressing this button. Use this function to identify the unit connected

BT OFF: Switch off the AHlink signal on the device. It will close the AHlink App connection

AUTO ADJUST: This function auto adjust the speed and mechanical protection of the unit. The unit will starts to go automatically Up and Down in order to auto adjust the speed and the mechanical protection parameters

MOV
Controls the Up and Down screen movements

MIC
Controls the microphone on PA mode

RED/ GREEN/ OFF: Controls the LED ring in conference mode

COMMAND: Information of the last AHnet command received from RS422 port



AHNET ADDRESS: Configuration of the AHnet address of the unit password

MIC LENGHT: Microphone length configuration in steps. One step is aprox. one cm

TERM: Configuration of the RS422 termination. Activate the RS422 termination only in the last unit of the RS422 Bus

MODE: Dynamic Talk working mode. PA mode is used for standard XLR3 microphones: the microphone is controlled by the Dynamic Talk and the LED ring indicates the state of the microphone (green – MUTE/ red – TALK). In conference mode, the external conference system controls the microphone and the LED ring is controlled using the GPI connector

PASSWORD: Password needed to access the technical configuration page

INFORMATION ON DISPOSAL FOR USERS OF WASTE ELECTRICAL & ELECTRONIC EQUIPMENT



This symbol on the products and/or accompanying documents means that used electrical and electronic products should not be mixed with general household waste.

For proper treatment, recovery and recycling, please take these products to the designated collection points, where they will be accepted on a free of charge basis. Alternatively in some countries, you may be able to return your products to your local retailer upon the purchase of an equivalent new product.

Disposing of this product correctly will help save valuable resources and prevent any potential negative effects on human health and the environment, which could otherwise arise from inappropriate waste handling. Please contact your local authority for further details of your nearest designated collection point.

Penalties may be applicable for incorrect disposal of this waste, in accordance with national legislation.

For business users in the European Union

If you wish to discard electrical and electronic equipment, please contact your dealer or supplier for further information.

Information on disposal in countries outside the European Union

This symbol is only valid in the European Union. If you wish to discard this product, please contact your local authorities or dealer and ask for the correct method of disposal.

WARRANTY TERMS AND CONDITIONS

Albiral Display Solutions warrants this product against manufacturing defects and workmanship for a period of two (2) years from the date of purchase, subject to the conditions below.

1. Electrical, electronic boards, accessories and power supply are warranted against manufacturing defects and workmanship for a period of two (2) years from the date of purchase
2. Labour costs: Albiral Display Solutions covers the labour costs to replace any defective parts during the validity of this warranty.
3. Transport costs:
 - 5.1. In the case that a manufacturing defect occurs within 90 days after the purchase date, both freight and insurance costs will be paid by Albiral Display Solutions.

Although Albiral Display Solutions S.L. pays for freight and insurance costs, Albiral Displays Solutions will not be responsible for any damages caused by the transportation of the goods if the customer does not inform in writing when receiving the goods.

- 5.2. After 90 days of the purchase date, the beneficiary of the warranty will pay both freight and insurance costs.

Albiral Display Solutions S.L. will not be responsible for any damages caused by transportation, when this one is paid by the customer.

4. This warranty does not cover the labour costs of handling, diagnose, removal, replacement, reinstall and/or program any product.
5. This warranty does not apply if the fault has been caused by misuse, improper handling, electrical or mechanical abuse, abnormal operation conditions, non-authorized modifications, and inadequate transportation or as a result of atmospheric phenomenons.

WARRANTY TERMS AND CONDITIONS

6. The warranty is not valid if people other than authorised Service Centre have handled the product and if the product has been manipulated or warranty seals are removed or manipulated.
7. The beneficiary of the warranty will have to return the product with the original packaging to warranty there are no damages during transportation.
8. The warranty is not valid if the beneficiary of the warranty does not include a RMA form and a copy of the purchasing invoice.

Please note that laws vary from country to country, and the same provisions of this warranty may not apply to you.

If you have any doubts concerning the terms of this warranty, please contact:

business@albiral.com

+34 938 502 376

Copyright ©

Nov. 2020. All rights reserved

Albiral Display Solutions SL.

Registered trademarks: Albiral, Arthur Holm

**Albiral
Display
Solutions**

Fàtima 25, Sant Hipòlit de Voltregà
08512 Barcelona – Spain
tel: +34 93 850 23 76 / 23 83
fax: +34 93 850 25 50 / 23 72
web: www.arthurholm.com
e-mail: marketing@arthurholm.com

Patents

MU17180ES00	P27178ITEP
MU17301ES00	P27178RUPC
MU17322ES00	P27178USPC
MU17413ES00	P27284DEEP
MU17445ES00	P27284EPPC
MU17854ES00	P27284ESEP
MU17868DEPC	P27284GBEP
MU17868RUPC	P27284RUPC
P24821DEEP	P27284USPC
P24821ESEP	P27715ESEP
P24821GBEP	P28089DEEP
P24821USPC	P28089ESEP
P27178DEEP	P28089ITEP
P27178EPDV01	P28089USPC
P27178EPPC	P28090EP00
P27178ESEP	P31160ESES
	P31160PCES