

1 – Pass the device black tube trough the table hole

2 – Point the device to its correct position

3 – Wedge the monitor to keep it vertically.

IMPORTANT: The Bracket Ring has mounting position to fix the device correctly with the table.
The side with 2 screws must be in the back side of the monitor.

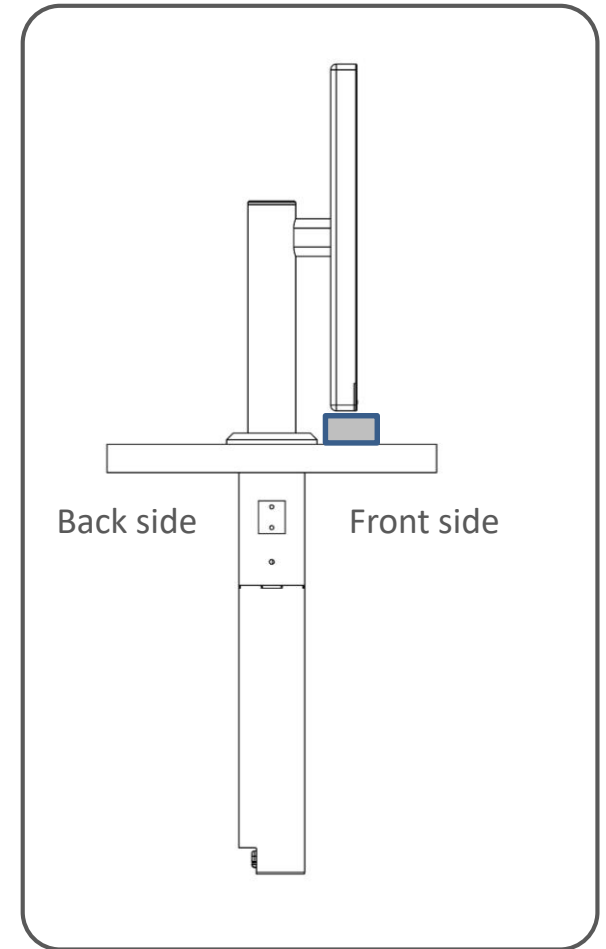

4- Mount the Pressing Screws on to the Bracket Ring so the screw is flushed with the upper side of the ring.

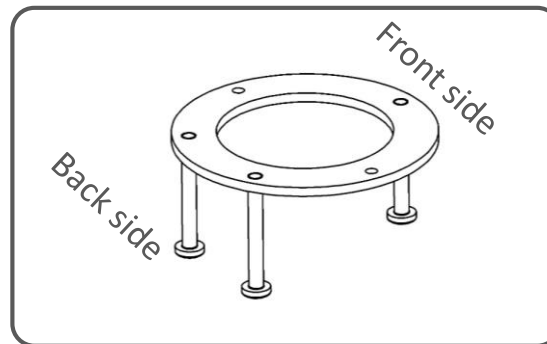

5 – Under the table: Pass the Protective and the Bracket ring trough the device.

6 – Mount the side Brackets.

IMPORTANT: Use the washer and the screw supplied (Using washer the maximum screw length can be 8mm, without washer 6mm)

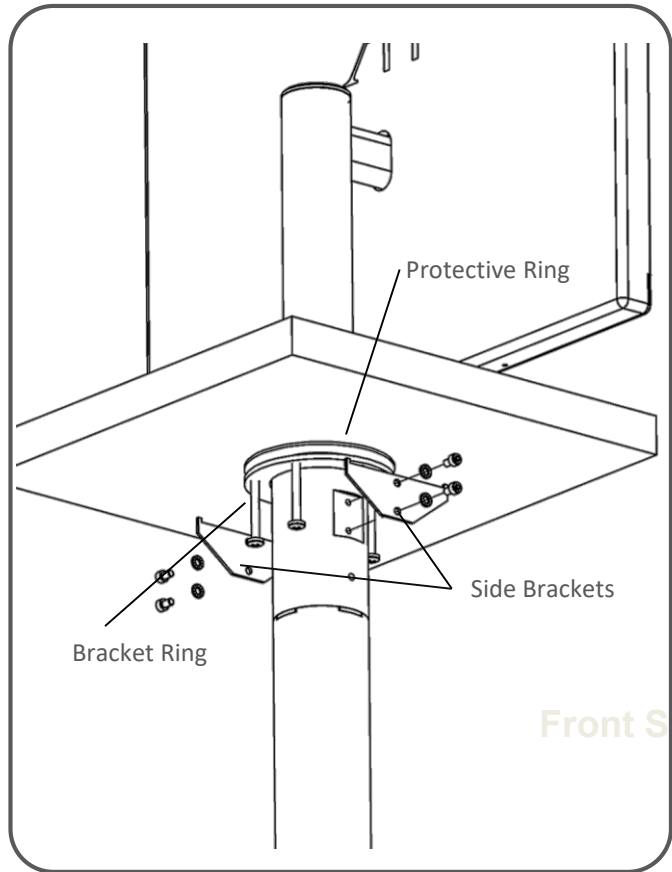

6 – Tighten the Pressing Screws gradually.

Remember that the 2 Pressing Screws must be in the back side of the monitor

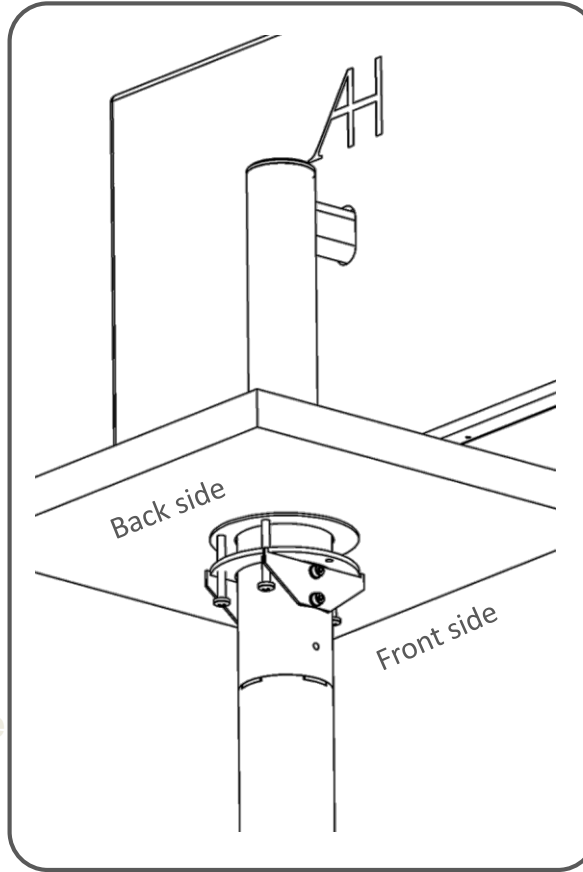

7 – Assemble and tighten the Side Pressing Screws.

